



INTERNATIONAL
Water·Guard

IWVG-M2

International Water-Guard AIRCRAFT WATER MODULE

- Compact, modular and easy to integrate*
- Easy to configure faucet, tank and hoses for any installation*
- Light weight*
- Simple, intuitive operation*
- Maintenance free*
- Optional Ultraviolet Water Disinfection*

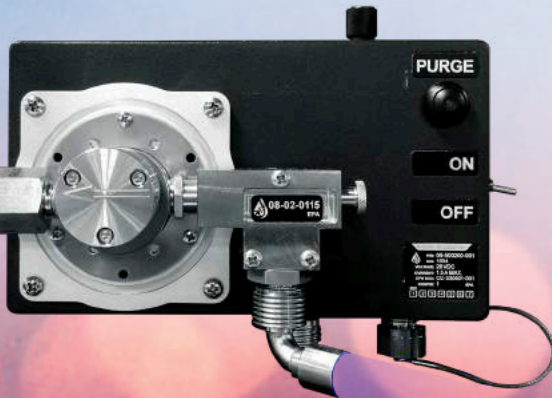



Designed for simple, intuitive operation, the IWG-M2 delivers pressurized cold water to an aircraft's lavatory vanity or galley at 2 litres per minute (0.5 gpm).

The IWG-M2 comes with a configurable faucet that features an electrical push button to activate the flow. The flow is electronically timed, and the timing adjustable depending on the end-user's requirements.

The tank is available in different water volumes and is configurable for any installation. It features easy access for cleaning, a large ergonomic spout for easy in-situ filling or for draining and a convenient carry handle.

The system can be automatically purged with the press of a button for added convenience.

Manufactured using materials that meet NSF61 - the IWG-M2 is safe, robust and disinfectant resistant.

IWG can design and manufacture any integration and retention equipment that may be required for your installation.

Backed by IWG's legendary customer service, the IWG-M2 is the simple way to add water to your cabin. Contact us today to find out more.

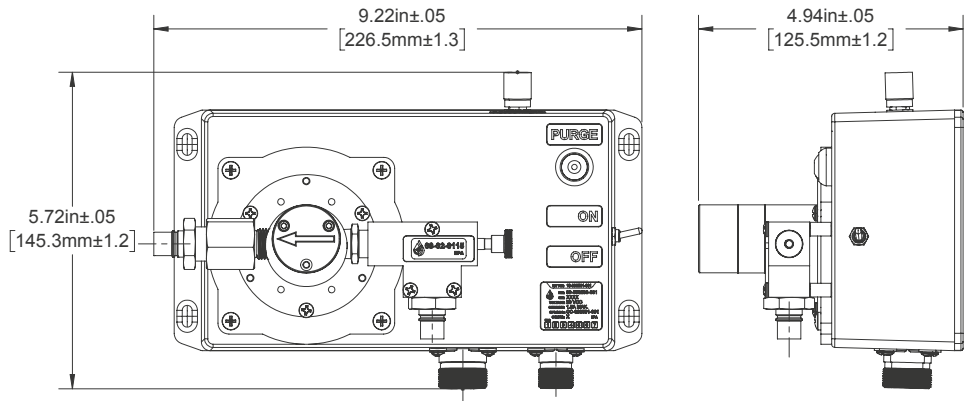

The IWG-M2 is a smart new modular water system designed specifically for the aviation market using proven technology from the IWG-M1. It is certified to FAR/CS Part 25 and comprehensively tested to DO-160G.

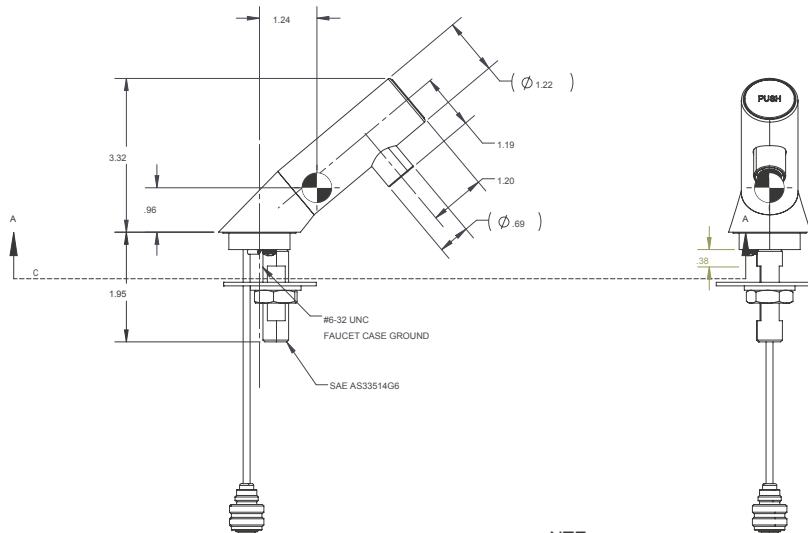

PHYSICAL

Overall Dimensions:

Net Weight Dry:

Controller Module: 4.5 lbs (2.0 Kg)

Faucet: 1.8 lbs (0.8 Kg)

Net Weight Dry:

Tank: 9.7 lbs (4.4 Kg) 18 litre version

Dimensions as shown ▶

Electrical

Input Voltage: 28 VDC

Nominal Current Draw: Max 1.5 A, idle 50 mA

Electrical Interface: EN3646A61006AN

Performance

Flow Rate: 2 lpm (0.5 gpm)

Pressure: 2.1 bar (30 PSI)

