



INTERNATIONAL
Water-Guard



The IWG-HE 210W Water Heater is a revolutionary lavatory heater featuring new technology which has been designed as a drop-in replacement for existing "cartridge" style lavatory heaters on aircraft.

The innovative heater element (patent pending) and thermal mixing valve achieve greater heating efficiency at a reduced size and weight. It also results in a reduction in scaling and bacterial buildup due to flow-through hydraulics and the higher in-chamber temperatures. The heater also features improved construction materials and methods over existing heaters, eliminating common corrosion issues. The result is a heater that is more efficient, more reliable and will save on operational costs both because of greatly reduced maintenance efforts and weight savings.

IWG-HE210

HIGH EFFICIENCY WATER HEATER SERIES FOR AIRBUS AIRCRAFT



INTERNATIONAL
Water-Guard

INNOVATION

IWG-HE-Flow Through Heater

Uses an innovative heating concept that improves the heating process and reduces scale build-up.

Complies with OSHA recommendations for heated vessels to operate at temperatures that kill Legionella, Pseudomonas Aeruginosa, and other pathogens.

Existing heaters operate at temperatures that allow pathogens to grow and establish biofilms.

Integrated thermal mixing valve provides precise control of outlet water temperature to the faucet.

P/N 09-270210-001_SA

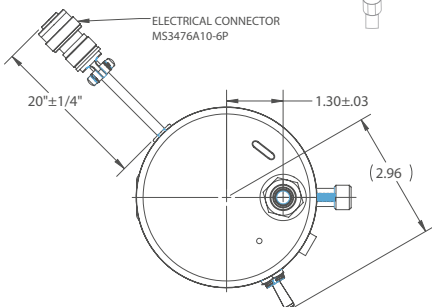
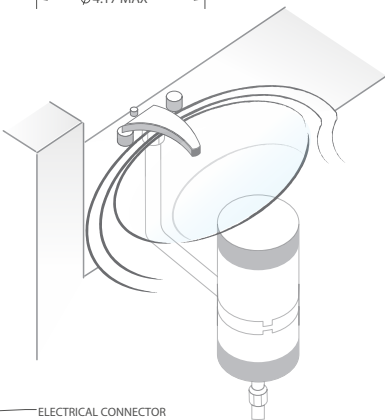
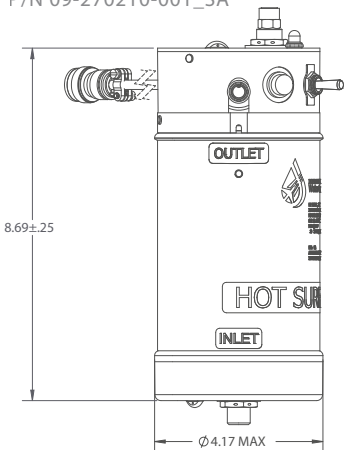

IWG-HE210

HIGH EFFICIENCY WATER HEATER SERIES FOR AIRBUS AIRCRAFT



PHYSICAL

- Max Net Dry Weight: 3.2 lbs (1.4 Kg)
- Wet Weight: 4.9 lbs (2.2 Kg)
- Volume: 0.21 Gal (0.8 L)
- Hydraulic Interface: SAE AS33514G6 (Flareless)

Performance

Inlet Pressure: 12-25 psig
Nominal Flow Rate: Up to 1.0 GPM
Adjustable Temperatures: 90-130°F (32-54 °C)

Electrical

Input Voltage: 115 VAC 60 - 800 Hz
Current Draw: 1.83A
Electrical Connector: MS3676A10-6P

INSTALLATION

- Drop-in replacement, LAV mod not required

BENEFITS

- Faster recovery time
- Longer hot water flow times
- Reduced scale build up
- More compact
- Reduced weight
- Helps protect passengers from harmful bacteria

QUALIFICATION

- DO-160G Qualified
- NSF61 Compliant
- PMA Certification in mid 2019

PERFORMANCE

- Heats faster with reduced recovering time
- Provides longer hot water flow

International Water-Guard Industries Inc.

Building #7 - 15050 - 54A Avenue | Surrey, BC, V3S 5X7, Canada

P 604.255.5555 | F 604.255.5685 | info@water.aero | www.water.aero